

THEORY & OBJECTIVE

# MACHINE DESIGN

*By  
Team of  
Engineers Academy*

- State Engineering Services Examinations.
- Public Sector Examinations.
- JEn (SSC, DMRC & State Level).
- Other Technical Competitive Exams.



**ENGINEERS ACADEMY<sup>®</sup>**

**Your GATEway to Professional Excellence**

**IES • GATE • PSUs • JTO • IAS • NET**

**CORPORATE OFFICE**

100-102, Ram Nagar, Bambala Puliya, Tonk Road, Pratap Nagar, Jaipur-302033

**Ph.: + 91-8094441777**

**Website : [www.engineersacademy.org](http://www.engineersacademy.org) | Email: [info@engineersacademy.org](mailto:info@engineersacademy.org)**

Ajmer | Jaipur | Kota | Jodhpur | Bhilwara | Delhi | Patna | Lucknow | LPU | Ludhiana | Jalandhar | Kanpur | Allahabad

# CONTENTS

S.No.	TOPIC	Page No.
1.	Introduction to Machine Design .....	1 – 3
2.	Static Loading .....	4 – 7
3.	Fatigue .....	8 – 21
4.	Design of Joints .....	22 – 66
5.	Clutches .....	67 – 74
6.	Power Screw .....	75 – 86
7.	Rolling & Sliding Contact Bearings .....	87 – 106
8.	Gears .....	107 – 124
9.	Brakes .....	125 – 135
10.	Practice Sheet .....	136 – 156



National Help Line : +91-8094441999, +91-8094441777

Website : [www.engineersacademy.org](http://www.engineersacademy.org) | Email: [info@engineersacademy.org](mailto:info@engineersacademy.org)

Ahmedabad | Allahabad | Ajmer | Bhilwara | Jaipur | Jalandhar | Jodhpur

Kota | LPU Campus | Lucknow | Ludhiana | Patna



# INTRODUCTION TO MACHINE DESIGN

## THEORY

### 1. ENGINEERING DESIGN

- (i) Mechanical Engineering Design
- (ii) Civil Engineering Design
- (iii) Electrical Engineering Design
- (iv) Chemical Engineering Design etc.

Problem of Society → Engineering Design → Product, device or system.

Resources men, material, machine, money → Engineering design → Product, device or system to satisfy human need.

Engineering design as iterative decision making activity to produce, a plan or drawing to convert resources optimally into a product or device or system to satisfy the human need.

- The ultimate aim of design is to develop a drawing [i.e. to select an appropriate shape, material, size and manufacturing process details] in such a way that the resulting machine component will perform given functionality satisfactorily (i.e. without fracture).

A machine component is said to be failure when it doesn't perform given objective satisfactorily.

- A machine is defined as a combination of stationary and moving machine elements and they are assembled in such a way that either to produce or transform or utilize mesh energy. Ex. motor, engine turbine, generators, pump, compressor, automobile machine etc.

#### 1.1 Steps used in design of a machine element:

- (i) Specify function of machine element

*Example:* Shaft load = kN at N = rpm

- (ii) Analysis (determination of load acting of machine element]

*Example:*  $T = \frac{P \times 60}{2\pi N} \times 10^6 = \text{--- Nmm}$

- (iii) Selection of appropriate shape for a given X s/c

*Example:* Circular X s/c

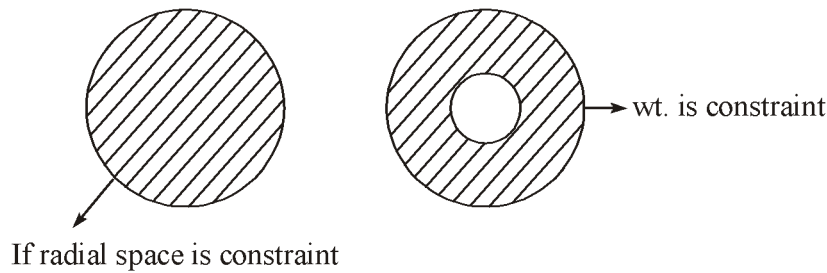

- (iv) Selection of appropriate material. Here after selection of material mechanical properties are noted down.

*Example:* Low power transmission → M/S. [Low (Steel)]

High power transmission → HCS or Ni, Ni – (steel)

- (v) Modes of failure
- (a) Failure of material by yielding system
  - (b) Failure by fracture system.
  - (c) Failure by excessive deformation.
- (vi) Calculation of dimension by using- strength of material equation like strength criterion or rigidity criterion
- (vii) Selection of manufacturing Process.
- (viii) Preparation of drawing.

## 1.2 Basic Requirement of Machine Element :

High strength → High rigidity → Low weight → Low service life → Low cost → High wear resistant.

## 1.3 Design Criterion:

Strength criterion → maximum stress induce ≤ permissible, based on permissible stress → rigidity criterion or stiffness criterion-based on permissible deformation.

*Example:* Shaft, spring, beam, machine tool because deformation effects the functionality of member or performance of machine element hence designed by Rigidity criterion.

Maximum deformation ≤ permissible deformation.

## 1.4 Factor of Safety:

Used to determine permissible stress given by

$$N = \frac{\text{Failure stress}}{\text{permissible or safe or allowable stress}}$$

The failure stresses are :

Yield strength for Ductile material

Ultimate strength for Brittle material

Inductance limit for fatigue load

reserve strength = feature stress – permissible stress

➤ **Reason to Keep Reservic Strength :**

- (1) Unknown environmental and loading conditions.
- (2) Imperfect workmanship.
- (3) Unreality of assumption made in basis some equations.
- (4) Stress conc. effect.

FOS can also be called as Factor of Ignorance.

## 1.5 Machine Design:

Design is a decision making process which is used to satisfy human need and to create something with physical reality.

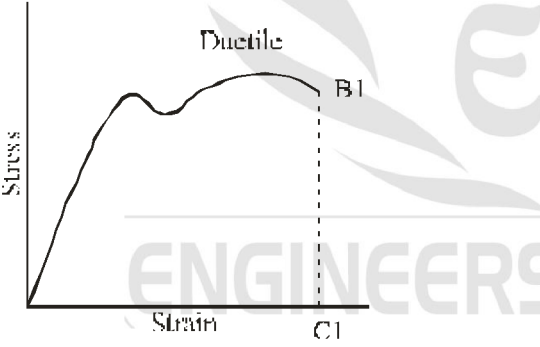
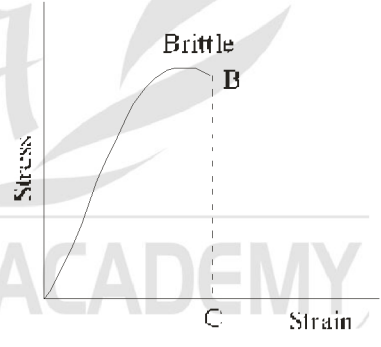
	<b>Ductile Material</b>		<b>Brittle Material</b>
<b>1.</b>	Resistance to yielding < Resistance to separation	<b>1.</b>	Resistance of separation < Resistance to yielding
<b>2.</b>	Failure takes place by yielding	<b>2.</b>	Failure takes place by separation
<b>3.</b>	$(\sigma_y)_{tension} = (\sigma_y)_{compression}$	<b>3.</b>	$(\sigma_{OTS})_{tension} \neq (\sigma_{ITS})_{comp}$
<b>4.</b>	A Material like copper is known as ductile i.e. It will flow and can be drawn out into a wire without fracture	<b>4.</b>	Material such as Glass that can be extended but do not show plastic deformation and will easily fracture
<b>5.</b>	In Failure theories Yield strength is used for Ductile material	<b>5.</b>	In Failure theories Ultimate strength is used for brittle material
<b>6.</b>		<b>6.</b>	

○○○



# STATIC LOADING

## THEORY

### 1. STRESSES

The machine parts are subjected to various forces which are called as load. Due to load there is stress in machine elements.

$$\text{Tensile stress} = \text{Tensile load} / \text{resisting area.}$$

$$\text{Shear stress} = \text{tangential load} / \text{resisting area}$$

It is state of stress where stress is parallel to the surface of material, complainer with material X s/c.

- **Thermal stress:** This occur due to temperature change and if the deformation occurring due to temperature change is opposed.
- **Bending stress:** There are tensile or comparative stress only.
- **Torsional stress:** These are shear stress only. shear stress Produced when we apply the twisting moment to the end of a shaft about its axis is known as Torsional stress.
- **Bearing stress:** Stress that result from contact of Two members.

### 2. TYPES OF LOAD

- (i) **Static or dead load:** doesn't change its magnitude and direction.
- (ii) **Variable load:** Change in magnitude and direction of load occur.
- (iii) **Sudden or shock load:** Their loads suddenly applied or removed.
- (iv) **Impact load:** Sudden load when applied with some velocity.

### 3. STRESSES IN MACHINE PARTS

#### 3.1 Tensile or Compressive Stresses :

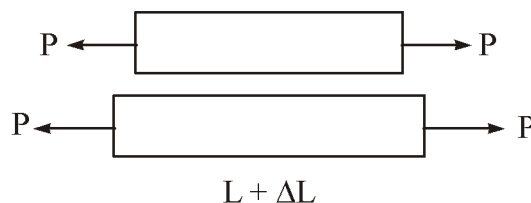

$$\text{Tensile stress} = \frac{P}{A}$$

$$\text{Strain} = \frac{\Delta L}{L}$$

$$\sigma = \epsilon E$$

$$\Delta = \frac{PL}{AE}$$

### 3.2 Shear Stress ( $\tau$ ) :

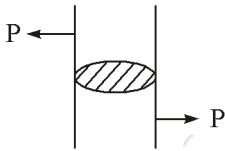

$$\tau = \frac{\text{tangential force}}{\text{resulting area}}$$

### 3.3 Bearing Stress :

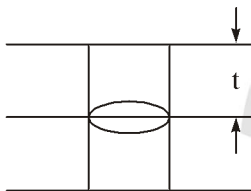

$$\sigma_b = \frac{P}{dt}$$

### 3.4 Thermal Stresses :

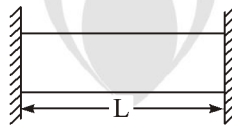

$t$  = Temperature change

$\alpha$  = Coefficient of thermal expansion

then

$$\delta L = L \alpha t$$

$$\frac{\delta L}{L} = \alpha t \text{ (thermal strain)}$$

then

$$\sigma_t = E \epsilon$$

$$\boxed{\sigma_t = E \alpha t}$$

### 3.5 Torsional Stress: It is zero at centroids areas and maximum at outer surface.

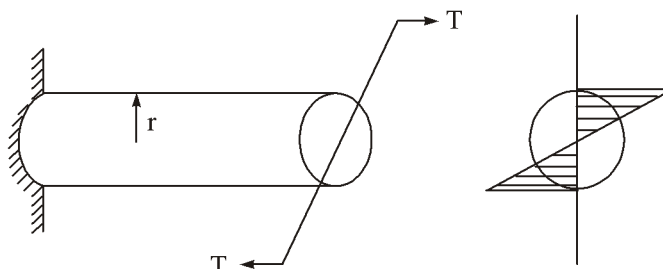

Torsion equation

$$\frac{\tau_s}{r} = \frac{T}{J} = \frac{G\theta}{L}$$

where

$\tau_s$  = Shear stress

$r$  = Radius of shaft

$T$  = Twisting moment

$J$  = Polar moment of Inertia

$G$  = Modulus of rigidity of shaft material

$\frac{T}{J} = \frac{\tau_s}{R}$  is known as strength equation.

$\frac{T}{J} = \frac{G\theta}{l}$  is known as stiffness equation.

and

Power = Torque  $\times$   $\omega$

**3.6 Bending Stress:** It occurs when a beam is subjected to bending moment.

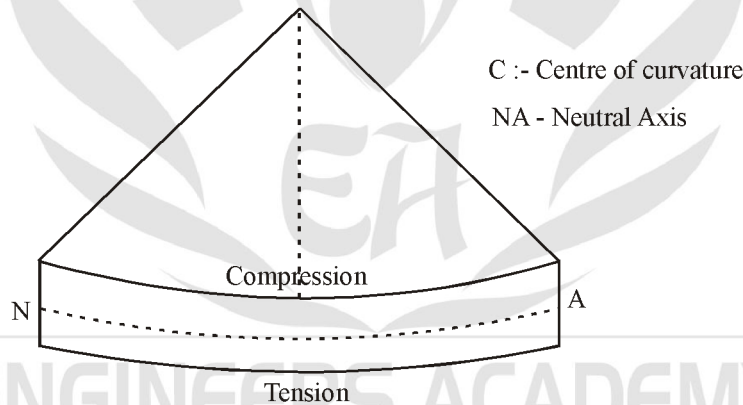

Bending equation

$$\frac{E}{R} = \frac{M}{I} = \frac{\sigma}{y}$$

$E$  = Young's modulus

$M$  = Bending moment acting at a given s/c

$\sigma$  = Bending stress

$I$  = MOI about neutral axis

$y$  = Distance from neutral axis to extreme fibre

$R$  = Radius of curvature of beam.

## 4. TYPE OF LOADING

### 4.1 Combined Bending and Torsion Stress:

Then we would calculate maximum shear and principle stress.

### 4.2 Eccentric Loading:

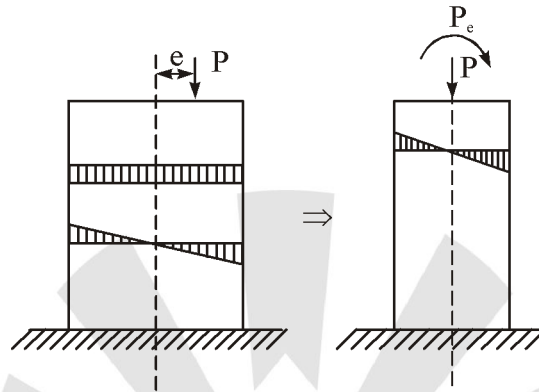

Maximum compressive stress

$$= \frac{-(P \cdot e) y_c}{I} - \frac{P}{A}$$

and maximum tensile stress

$$= \frac{(P \cdot e) y_t}{I} - \frac{P}{A}$$

○○○

ENGINEERS ACADEMY



# FATIGUE

## THEORY

### 1. VARIABLE LOAD

A material subjected to repetitive or Fluctuating stress will fail at a stress level much lower than required to cause fracture and failure occurring is called fatigue failure limit.

Sometimes this failure occurs without prior indications. The fatigue of material is affected by size, relative magnitude and static and fluctuating load and no. of load reversal.

### 2. FLUCTUATING STRESSES

In many applications, the components are subjected to forces, which are not static, but vary in magnitude with respect to time. The stresses induced due to such forces are called Fluctuating stresses.

It is observed that about 80% of failures of mechanical components are due to 'Fatigue Failure' resulting from Fluctuating stresses.

➤ There are three types of Mathematical model for cyclic stresses

- (i) Fluctuating or Alternating stresses
- (ii) Repeated stresses
- (iii) Reversed stresses

(i) *Fluctuating or Alternating Stresses :*

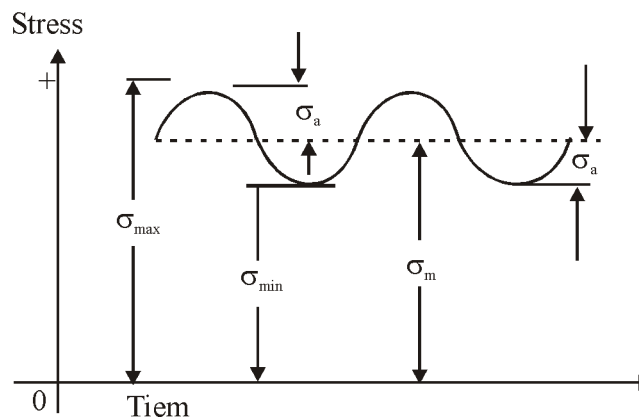

(ii) *Repeated Stresses:*

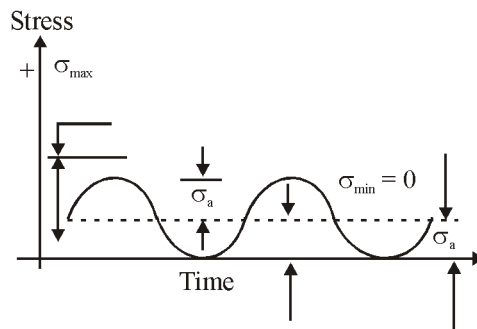

(iii) *Reversed Stresses :*

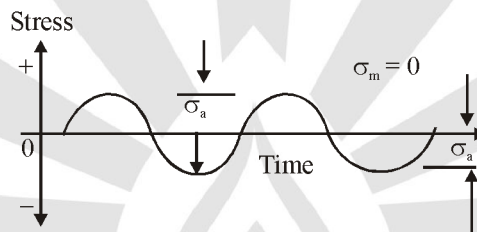

$\sigma_{max}$  and  $\sigma_{min}$  are maximum and minimum stresses, while  $\sigma_m$  and  $\sigma_a$  are called Mean stress and Amplitude stress.

$$\sigma_m = \frac{1}{2}(\sigma_{max} + \sigma_{min})$$

$$\sigma_v = \sigma_a = \frac{1}{2}(\sigma_{max} - \sigma_{min})$$

The Tensile Stress is Considered as positive While Compressive Stress as Negative.

The Repeated Stress and Reversed stress are Special cases of fluctuating stress with ( $\sigma_{min} = 0$ ) and ( $\sigma_m = 0$ ) respectively

### 3. FATIGUE FAILURE

- For example A wire can be cut very easily in few cycles of bending and unbending. This is a fatigue failure and magnitude of stress required to fracture is very Low.
- “Fatigue failure is defined as time delayed fracture under cyclic Loading”. examples of parts in which fatigue failure are common are Transmission Shafts, connecting rods, Gears, Suspension spring and boll Bearings.
- Fatigue cracks are not visible till they reach the surface of component and by that time the failure has already taken place. The Fatigue failure is sudden and total.
- The fatigue failure `depends upon number of factors such as the Number of cycles, mean stress, stress amplitude, stress concentration, residual stress, corrosion and creep.

### 4. ENDURANCE LIMIT

The fatigue or endurance limit of a material is defined as the maximum amplitude of completely reversed stress that the standard specimen can sustain for an Unlimited number of cycles without fatigue failure.

$10^6$  cycle is considered as a sufficient Number of cycles to define endurance Limit.

In laboratory the endurance limit is determined by means of a rotating Beam machine developed by **R.R Moore**.

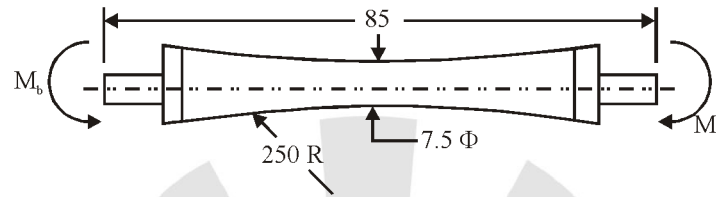

Principle of a rotating beam of circular cross section is subjected to bending moment ( $M_b$ ). and beam is subjected to completely reversed stresses with tensile stress in first half and compressive stress in second half.

$$\sigma_t \text{ or } \sigma_c = \frac{M_b Y}{I}$$

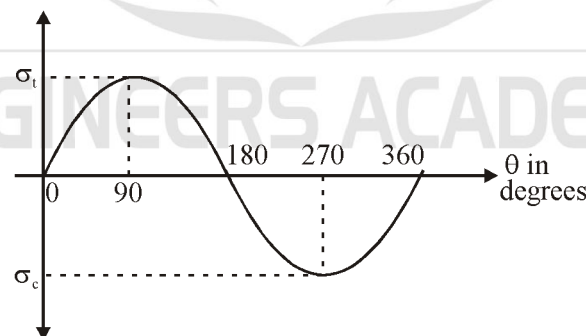
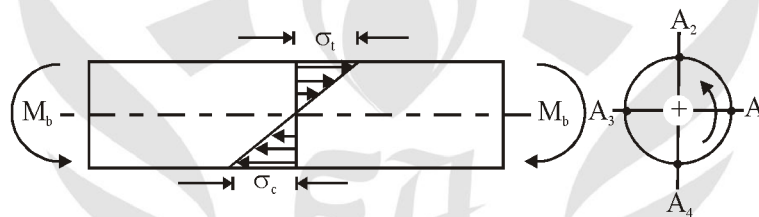

- The Results of Rotating beam fatigue testing machine are plotted by means of an S-N curve
- S-N curve is the graphical representation of stress amplitude ( $S_f$ ) Versus the number of stress cycles (N) before fatigue failure on a Log Log graph Paper.
- S-N Diagram is also called Wohler Diagram.

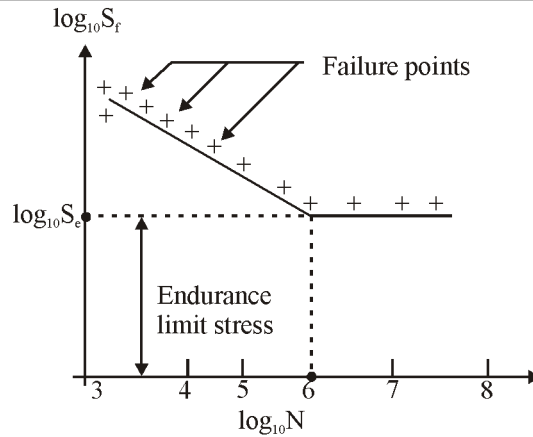

**S-N Curve for Steels**

*Note: Endurance Limit is not a Property of material like Ultimate tensile strength It is affected by factors such as size of component, shape of component, surface finish, temperature and Notch sensitivity of material.*

## 5. LOW CYCLE AND HIGH CYCLE FATIGUE

Any fatigue failure when number of stress cycles are less than 1000, is called low-cycle fatigue. Any failure when number of stress cycles are more than 1000 is called high-cycle fatigue.

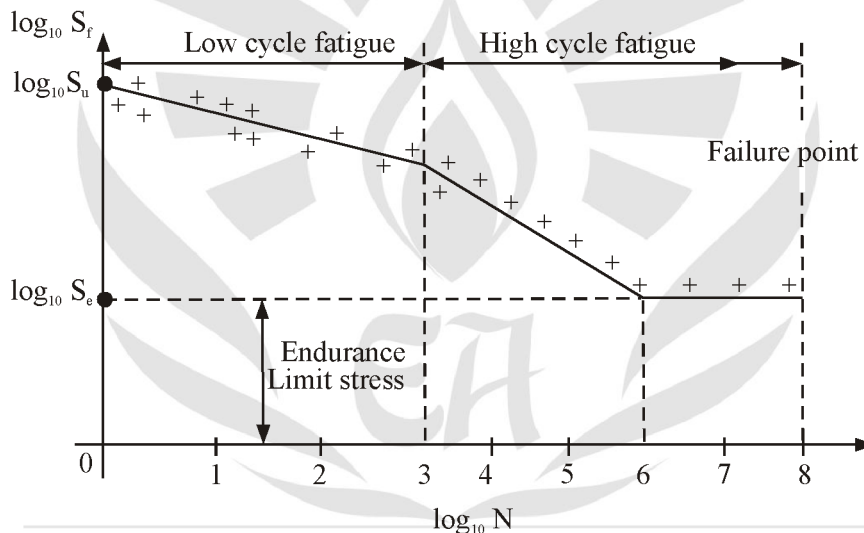

**Low and High Cycle Fatigue**

## 6. STRESS CONCENTRATION

Stress concentration is defined as the localization of high stresses due to the irregularities present in the component and abrupt change of the cross-section.

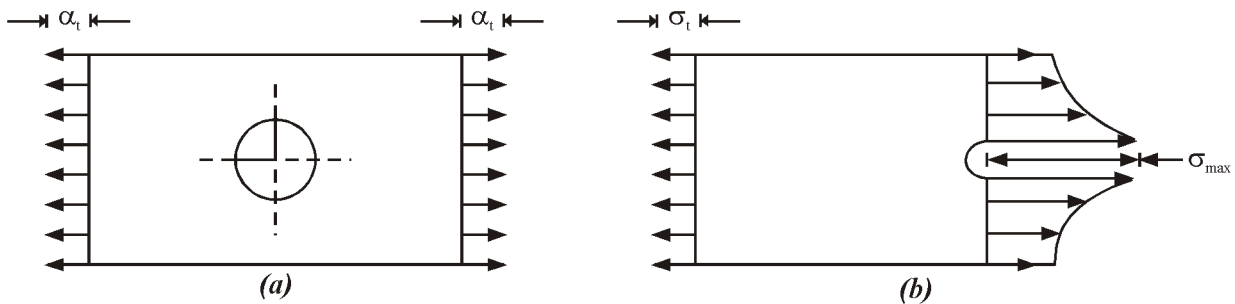

**Stress Concentration**

In order to consider the effect of stress concentrations, a factor called stress concentration factor ( $k_t$ ).

$$(k_t) = \frac{\text{Highest value of actual stress near discontinuity}}{\text{Nominal stress obtained by elementary equations for minimum cross-section}}$$

$$k_t = \frac{\sigma_{\max}}{\sigma_o} = \frac{\tau_{\max}}{\tau_o}$$

$\sigma_o$  and  $\tau_o$  are stresses determined by elementary equation.  $\sigma_{\max}$  and  $\tau_{\max}$  are localized stresses at Discontinuity. The magnitude of stress concentration factor depends upon the Geometry of Component.

### 6.1 Causes of Stress Concentration Factor :

- (i) Variation in Properties materials
- (ii) Load Application
- (iii) Abrupt change in section
- (ii) Discontinuity in Component
- (iv) Machining scratches

### 6.2 Stress Concentration Factor for Elliptical Hole :

According to theory of elasticity

$$k_t = 1 + 2\left(\frac{a}{b}\right)$$

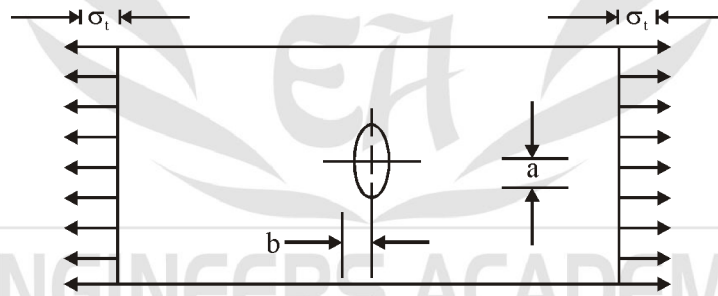

Stress Concentration due to Elliptical Hole

Where  $a$  = half width (or semi-major axis) of ellipse perpendicular to direction of Load

$b$  = half width (or semi-minor axis) of ellipse in direction of Load.

if  $b = 0$

then  $k_t = \infty$

if  $a = b$

then  $k_t = 1 + 2 = 3$

Therefore the  $k_t$  for small circular hole in a flat plate, which is subjected to tensile force is 3.

### 6.3 Reduction of Stress Concentration:

(i) Additional Notches and holes in tension member

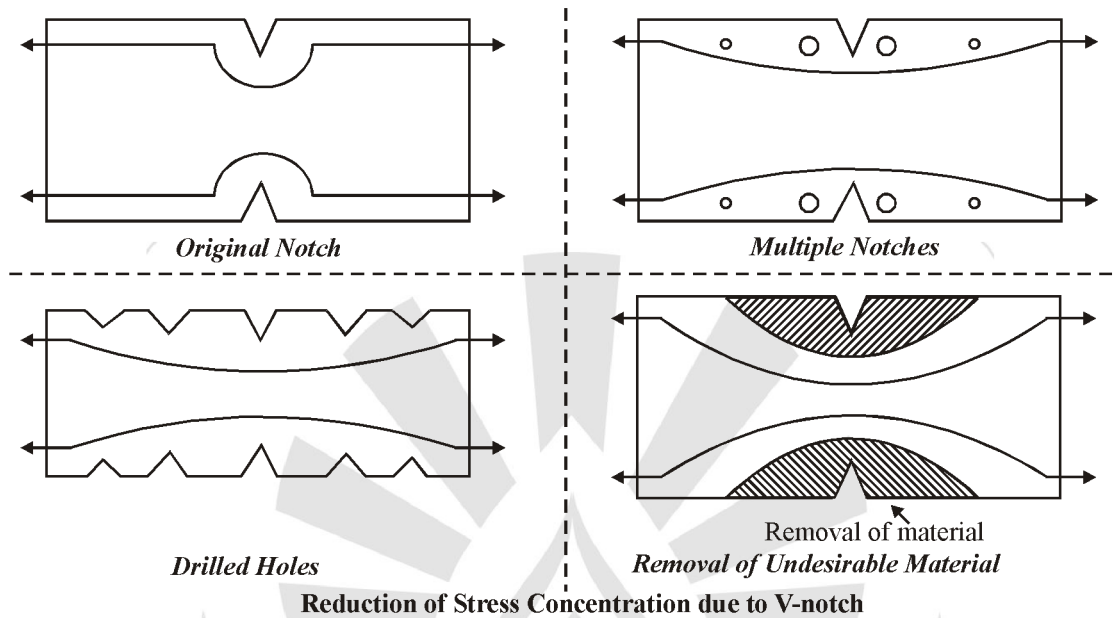

(ii) Fillet Radius, Undercutting and Notches for Member in Bending

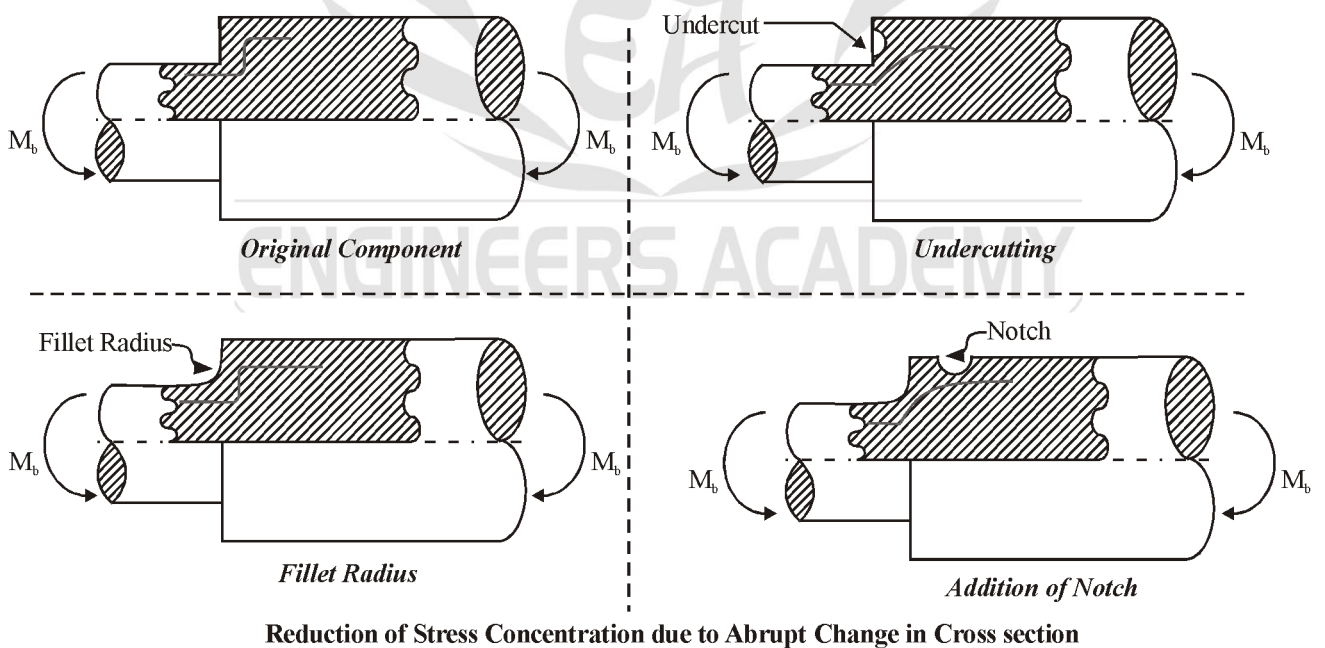

(iii) Drilling Additional holes for shaft

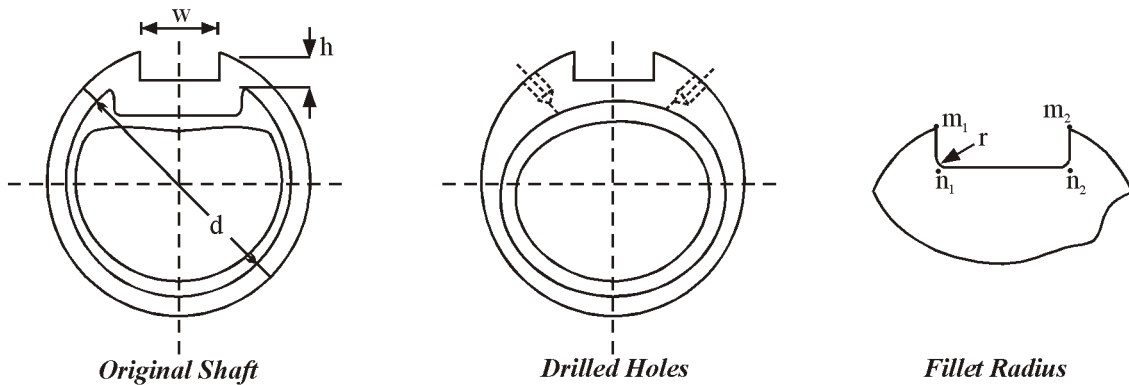

**Reduction of Stress Concentration in Shaft with Keyway:**

(iv) Reduction of stress concentration in threaded member

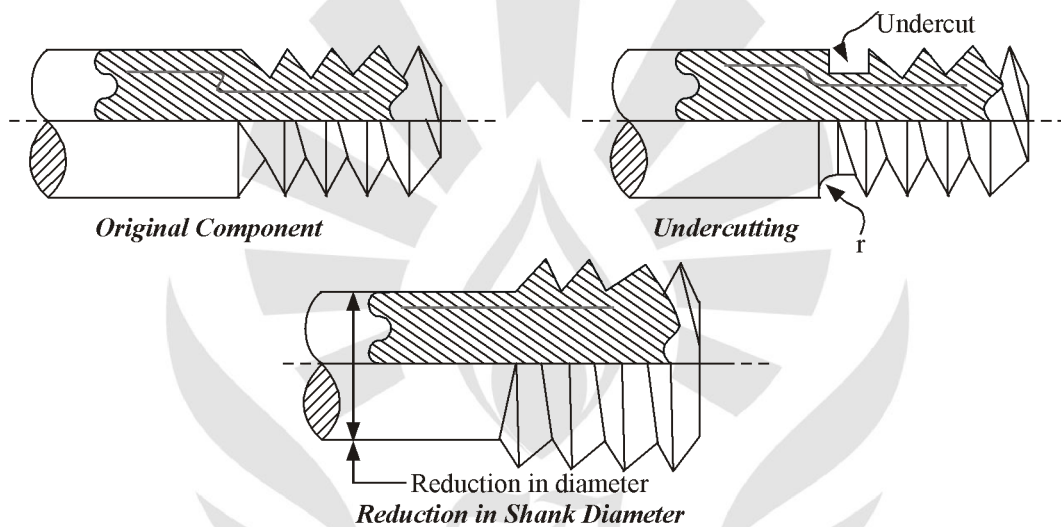

**Reduction of Stress Concentration in Threaded Components**

*Note: Stress concentration can be Reduce to some Limit but It can not be eliminate.*

### 7. FATIGUE STRESS CONCENTRATION FACTOR ( $k_f$ )

$$(k_f) = \frac{\text{Endurance Limit of the Notch Free Specimen}}{\text{Endurance Limit of the Notched Specimen}}$$

This factor ( $k_f$ ) is applicable to actual materials and depends upon the grain size of materials. the greater reduction in endurance limit of fine grained material as compared to coarse-grained materials, due to stress concentration.

### 8. NOTCH SENSITIVITY

“Noth sensitivity is defined as the susceptibility of a material to succumb to the damaging effect of stress raising notches in fatigue loading.”

The Notch Sensitivity factor ( $q$ )

$$(q) = \frac{\text{Increase of actual stress over nominal stress}}{\text{Increase of theoretical stress over nominal stress}}$$