

THEORY & OBJECTIVE

MEASUREMENTS

*By
Team of
Engineers Academy*

- State Engineering Services Examinations.
- Public Sector Examinations.
- JEn (SSC, DMRC & State Level).
- Other Technical Competitive Exams.



ENGINEERS ACADEMY[®]

Your GATEway to Professional Excellence

IES • GATE • PSUs • JTO • IAS • NET

CORPORATE OFFICE

100-102, Ram Nagar, Bambala Puliya, Tonk Road, Pratap Nagar, Jaipur-302033

Ph.: + 91-8094441777

Website : www.engineersacademy.org | **Email:** info@engineersacademy.org

Ajmer | Jaipur | Kota | Jodhpur | Bhilwara | Delhi | Patna | Lucknow | LPU | Ludhiana | Jalandhar | Kanpur | Allahabad

CONTENTS

S.No.	Topic	Page No.
1.	Characteristics of Instrument and Measurement Systems	1 – 4
2.	Analog Instruments	5 – 30
3.	AC Bridges	31 – 44
4.	Measurement of Power and Energy	45 – 55
5.	Cathode Ray Oscilloscope	56 – 66
6.	Instrument Transformer	67 – 72
7.	Miscellaneous	73 – 80



CHARACTERISTICS OF INSTRUMENT AND MEASUREMENT SYSTEMS

THEORY

MEASUREMENTS

1.1 DEFINITION

Comparison, between predefined standard and quantity to be measured, e.g. measurement of time. Two Requirement :

- (a) Multiplying ratio
- (b) Unit

Methods of Measurement

- (i) **Direct** : For Mass, Length & Time having low accuracy and precision.
- (ii) **Indirect** : In this measurement is carried out in stages, (high accuracy and sensitive)

1.2 TYPES OF MEASUREMENT

- (i) Mechanical- Large inertia, high weight, suitable for static and stable condition. Dynamic response is poor and fail to respond to transient condition. They have high inertia, large time constant, high response time. (can not sensed for 50 Hz AC)
- (ii) Electrical : Faster than mechanical. They have operating torque produced by some electrical principle and then deflection by mechanical displacement. They are unfit for very fast measurement.
- (iii) Electronic : it uses semiconductor devices. FET, Vacuum tubes or electron beam in CRO, have very low inertia and very fast response.

1.3 REQUIREMENT OF ELECTRONICS TYPE OF INSTRUMENTS

- (i) High Sensitivity
- (ii) Light and Compact
- (iii) Fast Response
- (iv) Low Power Consumption
- (v) Highly reliable

Speed : Electronic > Electrical > Mechanical Types

(i) **Absolute instruments:**

It gives magnitude of the quantity in terms of physical constant of instrument e.g. Tangent Galvanometer, Raleigh's current balance, Used in labs. It doesn't requires calibration.

(ii) **Secondary instruments :**

These instruments measures by comparison with an absolute quantity. Normally used e.g. Ammeter, Voltmeter, etc.

1.4 TYPES OF INSTRUMENT

- (i) *Indicating* : Ammeter
- (ii) *Recording* : XY Recorder
- (iii) *Integrating* : kWh meter (energy meter)
- (iv) *Unpolarized / Bipolar* : Can be used on both AC. and DC.
- (v) *Unipolar/Polarized* : Can not be used on both AC and DC.
- (vi) *Deflection* :

In this type due to some operating force, there is a mechanical displacement which shows the measurement. They are suited for dynamic conditions.

(vii) *Null* :

e.g. potentiometer, which is a comparison method. Its accuracy is better than deflection type. Its sensitivity is high. It is suitable for static measurements..

1.5 TYPES OF SIGNAL

- (i) *Analog* : Signal is continuous
- (ii) *Digital* : Signal is discrete.

1.6 CHARACTERISTIC OF INSTRUMENT

(1) Static

- | | | |
|---------------------|---|-----------|
| (a) Accuracy | } | desired |
| (b) Sensitivity | | |
| (c) Reproducibility | | |
| (d) Drift | } | undesired |
| (e) Static error | | |
| (f) Dead zone | | |

- (a) **Accuracy and Precision** : Accuracy is the closeness to true value get precision is a measure of reproducibility of the measurement. Accuracy require precision but precision does not require accuracy. Accuracy can be improved by calibration but precision cannot.

Accuracy is defined as closeness with the true value. True value is real value.

TYPE OF ACCURACY

- (1) *Point* : On a Particular Point
- (2) *FSD* : On FSD(Full scale deflection)
- (3) *True value* : Error is same for any measurement.

- (b) **Sensitivity** : It is the ratio of output signal / Input signal.

$$\text{Sensitivity} = \frac{\text{Small Change in output}}{\text{Small Change in input}}$$

- Sensitivity should be-high, its reciprocal is inverse sensitivity or deflection factor.
- Resolution : It is defined as smallest change in input which can be measured.
- **Scale Range and Scale Span** : Scale Range = difference between largest and smallest reading of instrument and span is Numerical difference between largest and smallest reading.

Range is 0 – 50 Amp

Ampere Span is 50 A

- (c) **Reproducibility** : It is the degree of closeness with, which a given value may be repeatedly measured or in other words measured value do not change with time.
- (d) **Drift** : Drift means variation in reading with respect to time.

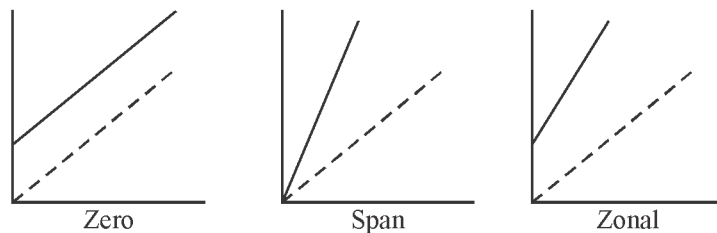

Note: In a measured quantity number of significant figures indicates precision e.g. 300. has 3 significant figures and 300.0 has 4 significant figures.

- (e) **Static error** : Measured value - True value. Also called absolute error.

$$\begin{aligned} \text{Relative error} &= \frac{\text{Absolute error}}{\text{True value}} \\ &= \frac{M_v - T_v}{T_v} \end{aligned}$$

Where, M_v = Measured value
 T_v = True value

$$\text{Static Correction} = -\text{Static error}$$

If Instrument is designed in terms of true value then error will be same for all the reading but if it is designed for FSD then error would be high for low reading.

- (f) **Dead zone** : Defined as largest change of input for which there is no output.

$$\text{Dead zone} = 2 \times \text{Hysteresis}$$

Deadtime : Time required to respond to change in measured.

Threshold : It is defined as smallest measurable input.

Example: 0-50 ammeter has accuracy of 1% of FSD. If current measured is 20 A find % error

Solutions :

$$\text{Error} = \frac{50 \times 1}{100} = .5A$$

Measured current = 20 A

$$\% \text{error} = \frac{0.5}{20} \times 100 = 2.5\%$$



PRACTICE SHEET**OBJECTIVE QUESTIONS**

1. Which one of the following statements is not correct
- (a) It is not possible to have precise measurements which are not accurate
- (b) Correctness in measurements requires both accuracy and precision
- (c) Reproducibility and consistency are expressions that best describe precision in measurements
- (d) An instrument with 2% accuracy is better than another with 5% accuracy
2. Match List-I with list-II and select the correct answer using the codes given below the lists:
- | List-I | List-II |
|----------------|--|
| A. Sensitivity | 1. Closeness to the true value |
| B. Resolution | 2. A measure of reproducibility of instrument |
| C. Accuracy | 3. Ratio of response to the change in the input signal |
| D. Precision | 4. Least interval between two adjacent discrete value |
3. Sensitivity of a voltmeter is expressed as
- (a) Volt/Ohms
- (b) Ohms/Volt
- (c) Ohms Volt
- (d) Amp/Volt
4. In measurement systems, which of the following are undesirable static characteristics:
- (a) Sensitivity and accuracy
- (b) Drift, static error and dead zone, linearity
- (c) Reproducibility and non-linearity
- (d) Drift, static error, dead zone and non-linearity

○○○

ANSWERS AND EXPLANATIONS

1. *Ans. (a)*
2. *Ans. (d)*
3. *Ans. (b)*
4. *Ans. (d)*

○○○



ANALOG INSTRUMENTS

THEORY

ELECTRICAL INSTRUMENTS

2.1 THE EFFECTS UTILIZED FOR THE OPERATION OF INSTRUMENTS

- (i) Magnetic effect (PMMC, MI, W)
- (ii) Induction effect (Energy meter)
- (iii) Hall effect (Transducer)
- (iv) Thermal effect (For thermocouple instrument)
- (v) Chemical effect (for D.C. Ampere hour meter)
- (vi) Electrostatic effect (for electrostatic voltmeters only)

2.2 CLASSIFICATION OF INSTRUMENTS

2.2.1 Absolute Instruments :

Absolute instruments are those instruments which give the value of the quantity to be measured in terms of constant, of the instruments & their deflection only. No previous calibration is required, example: tangent galvanometer, **Rayleigh's** current balance method for current & Lorentz method for resistance.

2.2.2 Secondary Instruments :

One those in which the value of electrical quantity to be measured can be determined from the deflection of the instruments only where they have been pre-calibrated by absolute instruments. Ordinary ammeter, voltmeter & watt meters belong to this category.

(i) *Indicating Instruments* :

Indicating Instruments are those which indicate the instantaneous value of the electrical quantity being measured at the time at which it is being measured. Example: Ammeters, voltmeter etc.

(ii) *Recording Instruments* :

Recording Instruments are those which instead of indicating by means of pointer and scale. The instantaneous value of an electrical quantity give a continuous record of the variations of such a quantity over a selected period of time.

(iii) *Integrating Instruments* :

Integrating Instruments are those which measures & registers by a set of dials & pointers either the total quantity of electricity (ampere-hour) or the total amount of electrical energy (kWh) supplied to a circuit in a given time.

Example: Ampere hour & watt hour meter.

2.3 ANALOG INSTRUMENTS

- (i) **Analog** : Continuous function of time.
- (ii) **Digital** : Discrete or in steps.

2.3.1 Principles of Operations :

(a) *Magnetic Effect* :

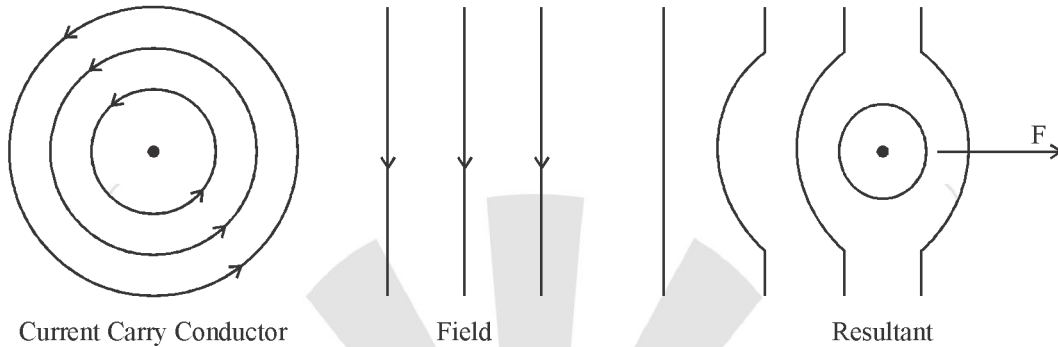

Current carrying conductor produced field. Dot shows upward current field is anti clockwise. If it is placed in magnetic field as shown then a force exerts as per left hand law or motor law.

$$F = BIL \text{ Newton Used in Ammeters and voltmeters.}$$

If magnet is permanent then it is used for D.C. (PMMC polarized). If magnet is electromagnet then it can be used for A.C./D.C. (Moving Iron) unpolarized.

(b) *Electrodynamic effect* :

It has two coils (fixed and moving), magnitude field produced due to the interaction of them (A.C./D.C.) unpolarized.

Used in Ammeters, Voltmeters and wattmeter.

(c) *Electromagnetic effect* :

Ammeter, Voltmeter, wattmeter, kWh meter.

(d) *Thermal effect* :

Due to heating effect, it measures current or voltage, Power AC (high frequency)/D.C.

(e) *Chemical effect* :

D.C. Amp hour meter.

(f) *Induction effect* :

AC (Voltage, Current, Power or Energy).

(g) *Electrostatic effect* :

High voltage D.C./A.C.

(h) *Hall effect* :

If a current carrying conductor is placed in a transverse magnetic field then an emf is produced which depends on current, flux density and material constant of conductor, called Hall effect.

2.3.2 Analysis of Motion :

$$F = \frac{Md^2x}{dt^2} + \frac{fdx}{dt} + kx$$

$$F(s) = Ms^2x + fsx + kx$$

$$\frac{X(s)}{F(s)} = \frac{1}{Ms^2 + fs + k} = \frac{\frac{1}{M}}{s^2 + \frac{f}{M}s + \frac{k}{M}}$$

$$\omega_n = \sqrt{k/M}$$

$$\xi = \frac{f}{2\sqrt{kM}}$$

Where,
For torque,

ω_n = Natural frequency

ξ = Damping ratio

$$\frac{\theta(s)}{T(s)} = \frac{1}{Js^2 + Ds + k}$$

Where,

J = Moment of Inertia

$$\omega_n = \sqrt{\frac{k}{J}}$$

D = Viscous friction

$$\varepsilon = \frac{D}{2\sqrt{KJ}}$$

K = Spring constant

2.3.3 Construction

(i) Moving System :

Should be light and friction should be less, weight can be reduced by using aluminum and friction can be reduced by using spindle mounted between jeweled bearings.

(ii) Supports :

Used to support the moving system.

TYPES OF SUPPORTS :

- (a) **Suspension:** has fine, ribbon shaped metal filament for upper suspension and coil of fine wire for lower part. This is used for high sensitivity work like in labs.
- (b) **Jewel bearings:** Moving system shaft mounted on bearings, friction is very less, arrangement is delicate, not very reliable.
- (c) **Taut suspension:** Taut suspension has a flat ribbon suspension above and below moving element. Not only supports but also provides controlling torque, advantages low friction, can be used either in vertical or horizontal position, good sensitivity

(iii) Torque/Weight ratio :

J, F, K should be very small, so that weight is reduced hence inertia is less and torque is more Torque/weight ratio reflects the sensitivity, Performance and reliability of instrument.

2.3.4 Types of Torque

(i) Deflecting Torque :

The deflection of the instrument (Deflecting Torque, T_d) is produced by utilizing the various effects like magnetic, electrodynamic, thermal or inductive effect The deflecting torque causes the moving system to move from its zero position

(ii) Controlling Torque :

The deflection of the moving system would be indefinite if there were no controlling or restoring torque. This torque opposes the deflecting torque & increases with the deflection of the moving system.

The pointer is brought to rest at a position where the two opposing torque's are equal. In the absence of controlling torque pointer would swing over to the maximum deflected position irrespective of whatever the magnitude of measured quantities.

There are two types of mechanism by which controlling torque are obtained.

(a) Spring Control :

A hair spring usually of phosphor bronze is attached to the moving system of the instrument. With the deflection of the pointer, the spring is twisted in the opposite direction.

This twist in spring produces controlling torque which is directly proportional to the angle of deflection of the moving system. The pointer comes to position of rest when deflecting torque & controlling torque are equal.

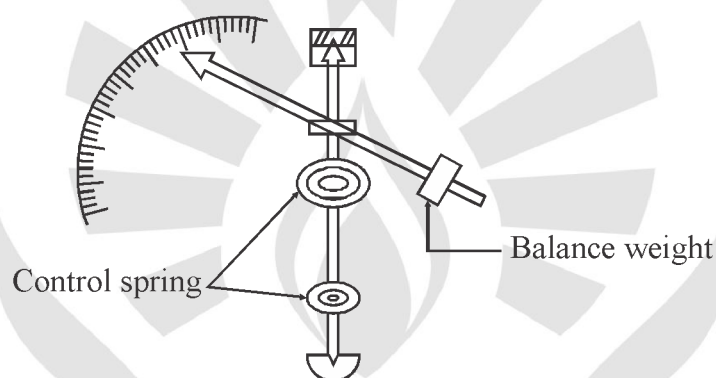

$$T_C = \frac{Ebt^3\theta}{12l} \text{ N-m}$$

Here,

E = Young's modulus of spring material

b = Width of Spring (m)

t = Thickness of Spring (m)

l = Length of Spring (m)

θ = Angular deflection (in radian)

$$T_C = K\theta$$

$$K = \frac{Ebt^3}{12l} \text{ N-m / rad}$$

Where,

K = Spring constant or torsion constant

Note : Spring material should be annealed to avoid fatigue and two springs in opposite direction are used to nullify temperature effect

Example: Spring has following dimensions, length = 370 mm, thickness = 0.073 mm, width = 0.51 mm, E = 112.8 GN/m², $\theta = 90^\circ$. Find torque exerted.

Solution : Given data

$$T_C = \frac{Ebt^3}{12l} \theta$$

$$= \frac{112.8 \times 10^9 (.51 \times 10^{-3}) \times (.073 \times 10^{-3})^3}{12 \times 370 \times 10^{-3}} \times \frac{\pi}{2}$$

$$= 7.9 \times 10^{-6} \text{ N-m}$$

Requirement of Spring :

- (1) It should be nonmagnetic
- (2) Should not be subjected to much fatigue
- (3) Should have low temperature resistance coefficient
- (4) It should have large number of turns

(b) Gravity Control :

Gravity control is obtained by attaching a small adjustable weight, to some part of the moving system such that the to exert torque in the opposite direction.

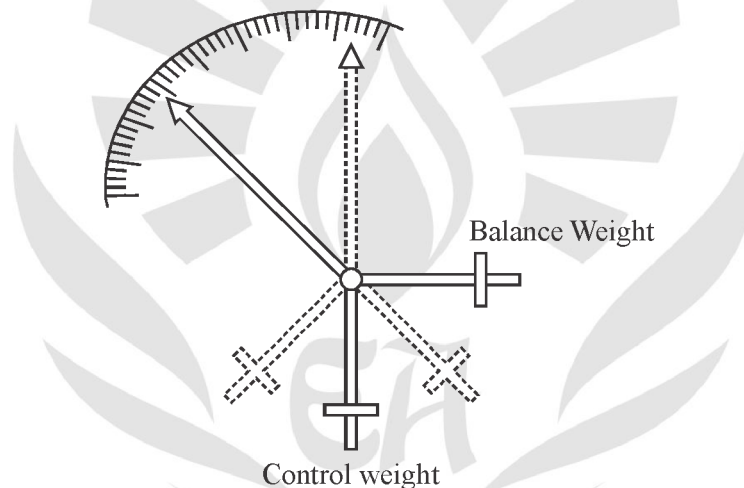

Controlling torque (T_C) is proportional to $\sin\theta$.

If $T_C \propto \sin\theta$
 and $T_d \propto i$
 then $T_d = T_C$ (At equilibrium condition)
 $i \propto \sin\theta$

Advantage of Gravity Control :

- (1) It is cheap.
- (2) It is unaffected by temperature
- (3) It is not subject to fatigue.

Disadvantages

- (1) It gives cramped scale.
- (2) The instrument has to be kept in vertical position.

(iii) Damping Torque :

A damping force is one which acts on the moving system of the instrument when it is moving & always opposes its motion. Such damping force is necessary to bring the pointer to rest quickly otherwise due to the inertia of the moving system. The pointer will oscillate about its final position for some time before coming to rest in the steady position. (Damping is less than 1, it should not be critically damped).

TYPES OF DAMPING SYSTEMS

(a) Air Friction :

As shown in figure a light aluminum piston is attached to the moving system of the instrument is arranged to travel in a fixed air chamber whose cross-section may be rectangular or circular, oscillations are damped out by compression & suction action of the piston on the air enclosed in the chamber.

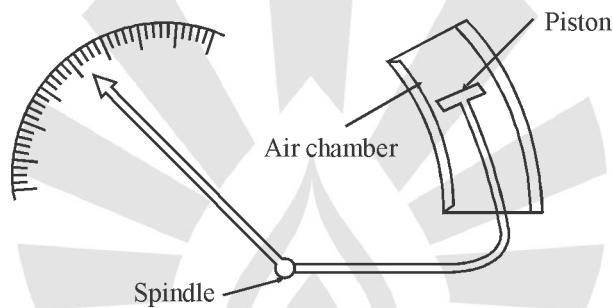

(b) Eddy Current Damping :

As shown in figure a thin disc of conducting but non magnetic material like copper/aluminum mounted on the spindle which carries the moving system. The disc is so positioned that its edges when in rotation at the magnetic flux between the poles of a permanent magnet hence eddy current are produced in the disc which produces a damping force in such a direction on to oppose the vary cause which is producing this (Lenz's Law). The cause is the rotation of the disc hence the force retards the motion of the disc and the moving system on the whole.

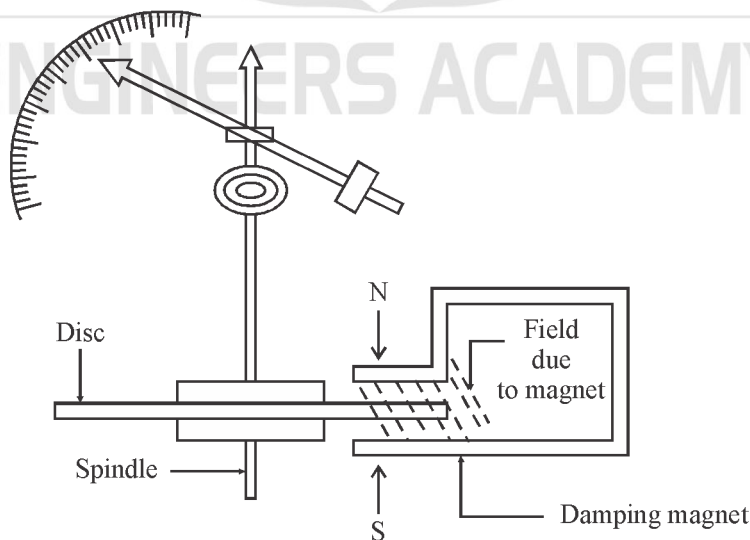

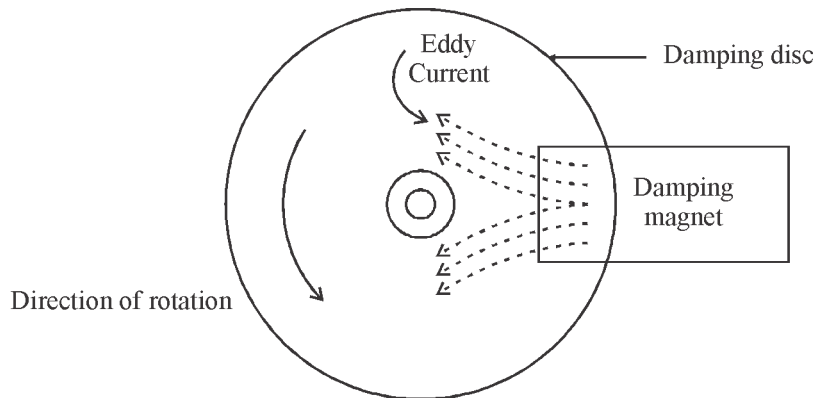

(c) **Fluid Friction :**

This damping consist of the force which damped out the vibration by viscosity of the oil. It is not preferable because of the creeping (disintegration) of the oil. Necessity of the instrument to kept in vertical position.

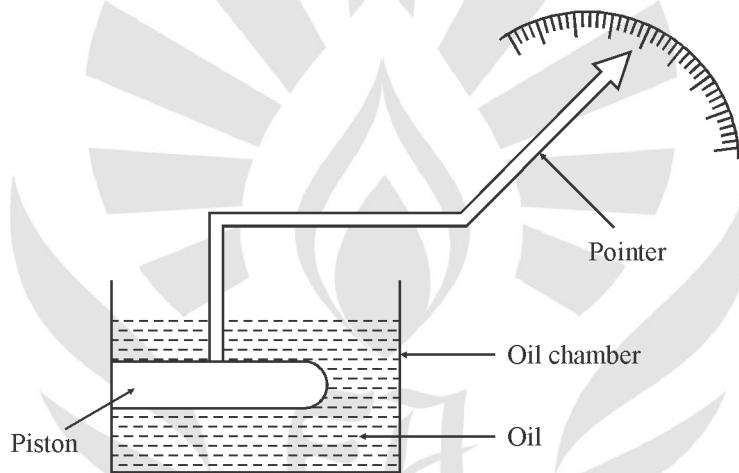

Example: The torque of an ammeter varies as the square of the current through it. If current of 10 Amp produces a deflection of 90°. What deflection will occur for a current of 6 amperes.

When the instrument is _____

- (i) Spring controlled
- (ii) Gravity controlled.

Solution : (i) **Spring controlled:**

	$i = 10 \text{ Amp}$
for	$\theta = 90^\circ$
	$i^2 \propto \theta$
	$\theta \propto i^2$
	$90^\circ \propto 10^2$
So,	$\frac{\theta_2}{\theta_1} \propto \frac{i_2^2}{i_1^2}$
	$\theta_2 = \theta_1 \cdot \frac{i_2^2}{i_1^2} = 90^\circ \frac{6^2}{10^2} = 32.4^\circ$

(ii) Gravity Controlled

$$i^2 \propto \sin\theta$$

$$\sin\theta \propto i^2$$

$$\frac{\sin\theta_2}{\sin\theta_1} = \frac{i_2^2}{i_1^2}$$

$$\sin\theta_2 = \sin\theta_1 \cdot \frac{i_2^2}{i_1^2}$$

$$\sin\theta_2 = \sin 90^\circ \cdot \frac{36}{100} = 1 \cdot \frac{9}{25} = 0.36$$

$$\theta_2 = \sin^{-1} 0.36 = 21.1^\circ$$

2.4 MOVING IRON INSTRUMENTS (AMMETER & VOLTMETER)

Moving iron type instrument may be attraction type or repulsion type. These are based on the principles of **minimum reluctance**.

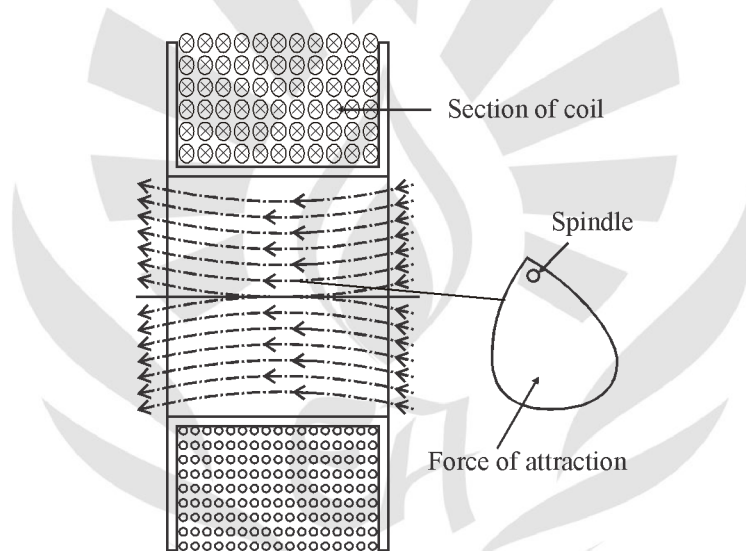

2.4.1 Working Principle of an Attraction Type Moving Iron (M.I.) Instrument

As shown in figure. Its consist of two electromagnets which produces a magnetic field according the current given and its consist of an oval shaped disc of soft iron on a spindle between bearings near coils. The iron disc will swing into the coil when the electric current passing through it pointer is' fixed to a spindle camping, the disc then the passage of current through the coil will cause pointer to deflect.

The deflection is proportional to the current flow in the coil.

These instruments can be used on A.C. as well as D.C. [Power frequency(0-125)Hz, Cheapest. Square response]

Deflecting Torque $T_d \propto I^2$

If spring control is used, then

Controlling torque $T_C = K \cdot \theta$

$T_d = T_C$ (At steady state)

Hence $\theta \propto I^2$

If gravity control is used, then $I^2 \propto \sin\theta$

- In both the cases the scales would be uneven.
- Air friction damping is provided.
- This instrument is of unpolarized type.

2.4.2 Sources of Error :

(A) Error with both AC & DC

Temperature error : Swamping resistance (manganin) is connected in series with meter.

(B) Error with AC only:

- (i) Change in frequency produced
- (ii) Change in impedance of the coil
- (iii) Change in the magnitude of eddy currents.
- (iv) Deflecting torque is not exactly proportional to the square of current due to nonlinear characteristics of iron metal

Note : Impedance of the circuit becomes independent of the frequency,

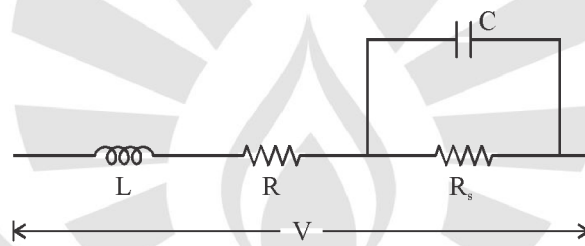

Where,

$C = \text{Capacitance}$
 $L = \text{Inductance of circuit}$
 $R_s = \text{Swamping resistance}$

Advantages

- (i) Cheap
- (ii) Robust
- (iii) Reliable
- (iv) Can be used on A.C. & D.C. (Universal use)
- (v) Low friction error (High τ/w Ratio)
- (vi) Scale range is 0 - 240°

Disadvantages

- (i) Nonlinear scale
- (ii) Can not be calibrated with high degree of precision with D.C.

2.4.3 Deflecting Torque in Terms of change in Self-induction

$$T_d = \frac{1}{2} I^2 \frac{dL}{d\theta} \text{ N-m}$$