

THEORY & OBJECTIVE

POWER ELECTRONICS

*By
Team of
Engineers Academy*

- State Engineering Services Examinations.
- Public Sector Examinations.
- JEn (SSC, DMRC & State Level).
- Other Technical Competitive Exams.



ENGINEERS ACADEMY[®]

Your GATEway to Professional Excellence

IES • GATE • PSUs • JTO • IAS • NET

CORPORATE OFFICE

100-102, Ram Nagar, Bambala Puliya, Tonk Road, Pratap Nagar, Jaipur-302033

Ph.: + 91-8094441777

Website : www.engineersacademy.org | **Email:** info@engineersacademy.org

Ajmer | Jaipur | Kota | Jodhpur | Bhilwara | Delhi | Patna | Lucknow | LPU | Ludhiana | Jalandhar | Kanpur | Allahabad

CONTENTS

S.No.	Topic	Page No.
1.	Introduction to Power Electronics	1 – 5
	Practice Sheet.....	6 – 13
2.	SCR	14 – 37
	Practice Sheet.....	38 – 47
3.	Phase Controlled Converters	48 – 68
	Practice Sheet.....	69 – 79
4.	Choppers	80 – 89
	Practice Sheet.....	90 – 96
5.	Inverter	97 – 114
	Practice Sheet.....	115 – 119
6.	AC Voltage Controller.....	120 – 125
	Practice Sheet.....	126 – 128
7.	Cyclo Converter	129 – 135
	Practice Sheet.....	136 – 138



ENGINEERS ACADEMY
PUBLICATIONS

Log on to : www.eapublications.org | Ph. : 08094441777



INTRODUCTION TO POWER ELECTRONICS

THEORY

1.1 INTRODUCTION TO POWER ELECTRONICS

Power Electronics is used to change the characteristics (Voltage and current magnitude and frequency) of electrical power to suit a particular application. It is an interdisciplinary technology.

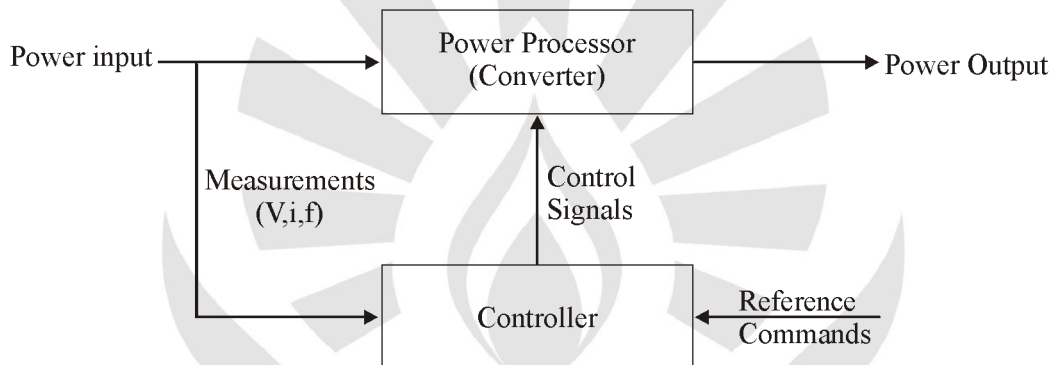

Power semiconductor devices can be categorized into three types based on their control input requirements:

- (a) Current-driven devices: BJTs, GTOs.
- (b) Voltage-driven devices: MOSFETs, IGBTs, MCTs.
- (c) Pulse-driven devices: SCRs, TRIACs.

1.2 POWER SEMICONDUCTOR DEVICE VARIETY

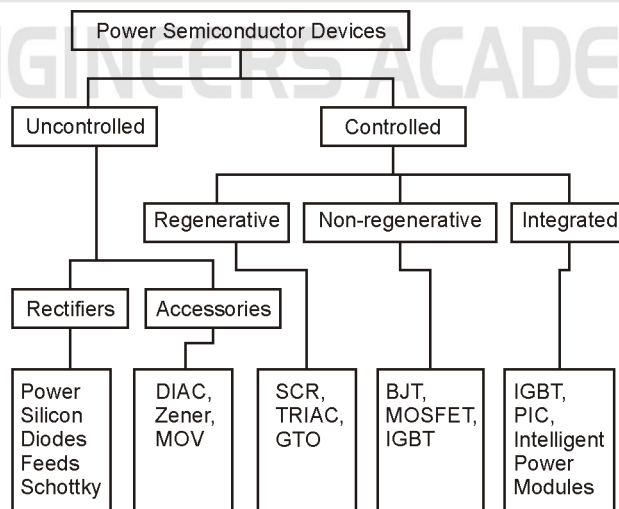

1.3 APPLICATIONS OF POWER ELECTRONICS**1.3.1 Transportation**

- (i) Electric/Hybrid Electric Vehicles
- (ii) Electric Locomotives
- (ii) Electric Trucks, Buses, Construction Vehicles, Golf Carts.

1.3.2 Utilities

- (i) Line transformers
- (ii) Generating systems
- (iii) Grid interface for alternative energy resources (Solar, wind, fuel cells, etc.) and energy storage.
- (iv) FACTS
- (v) HVDC
- (vi) Solid state transformer
- (vii) Solid state fault current limiter
- (viii) Solid state circuit breaker

1.3.3 Industrial/Commercial

- (i) Motor drive systems
- (ii) Electric machinery and tools
- (iii) Pumps/compressors
- (iv) Process control
- (v) Factory automation

1.3.4 Consumer Products

- (i) Air conditioners/Heat pumps
- (ii) Appliances
- (iii) Computers
- (iv) Lighting
- (v) Telecommunications
- (vi) Uninterruptible power supplies
- (vii) Battery chargers

1.3.5 Utility Systems:

- (i) High voltage DC transmission (HVDC)
- (ii) Excitation Systems
- (iii) VAR Compensation
- (iv) Static circuit breakers
- (v) Fans and boiler feed pumps
- (vi) Supplementary energy systems (solar, wind)

1.3.6 Medical Equipment:

1.4 DESIRABLE CHARACTERISTICS OF A POWER DEVICE

- (i) Small leakage current in off state.
- (ii) Small on-state voltage drop to minimize conductive losses.
- (iii) Short turn-on and turn-off times (high switching frequency.)
- (iv) Large forward and reverse voltage blocking capability so, minimizes need to series several devices to enhance a blocking capability.
- (v) High on-state current rating minimizes need to parallel devices.

1.5 TYPES OF POWER CONVERSION**(a) AC-DC converter (Rectifier) :**

Converts input AC to variable magnitude DC, e.g. battery chargers, computer power supplies.

(b) AC-AC Converter (Cycloconverter and AC voltage Controller) :

Converts input AC to variable magnitude variable frequency AC, e.g. ship propulsion systems.

(c) DC-AC Converter (Inverter) :

Converts input DC to variable magnitude variable frequency AC, e.g. electric/hybrid electric traction drives.

(d) DC-DC converter (DC Chopper-Buck/Boost/Buck-Boost Converter)

Converts input DC to variable magnitude DC, e.g. voltage regulators.

(e) DC-DC converters (Switched Mode Power Supplies (SMPS))

Make up about 75% of power electronics industry.

- (i) Power Supplies for Electronic Equipment
- (ii) Robotics
- (iii) Automotive/Transportation
- (iv) Switching Power Amplifiers
- (v) Photovoltaic Systems

(f) DC-AC-Inverter

- (i) AC Machine Drive (permanent magnet, switched reluctance, or induction machine)
- (ii) Uninterruptible Power Supply (UPS)
- (iii) Machine Tools
- (iv) Induction Heating-Steel Mills
- (v) Locomotive Traction
- (vi) Static Var Generation (Power Factor Correction)
- (vii) Photovoltaic or Fuel Cell Interface with Utility

(g) AC-DC-rectifier

- (i) DC Machine Drive
- (ii) Input Stage to DC/DC or DC/AC Converter
- (iii) Energy Storage Systems
- (iv) Battery Chargers
- (v) Aerospace Power Systems
- (vi) Subways, Trolleys
- (vii) High Voltage DC (HVDC) Transmission

(h) AC-AC Converters-Voltage Controller 1- ϕ to 3- ϕ Converters.

- (i) Lighting/Heating Controls
- (ii) Large Machine Drives

1.6 POWER TRANSISTORS

1. BJT
2. MOSFET
3. IGBT

1.6.1 BJT

- Bipolar device i.e. holes & electrons.
- Current controlled device.
- Low input impedance.
- Low ON-state voltage drop and lower conduction loss.
- Higher switching power losses.
- Secondary breakdown occur.
- Negative temperature coefficient because of negative temperature coefficient BJT are not advisable for parallel operation.
- Low conduction losses.
- Lower operating frequency (10 kHz).
- ON-state in saturation region.
- Controlled turn-on & turn-off device.
- Turn-on & Turn-off time depend on junction capacitances.
- Control signal requirement continuously.
- Ratings : 1400V, 400A, 10 kHz
- Switching period, $t_s = 50\mu \text{ sec}-100\mu\text{sec}$

1.6.2 MOSFET

- Unipolar device i.e. majority carrier device.
- Voltage controlled device.
- High input impedance.
- High-ON state voltage drop and higher conduction losses.
- Lower-switching power losses.
- Free from secondary breakdown.
- Positive temperature coefficient.
- Because of positive temperature coefficient, MOSFET are advisable for parallel operation.
- Higher conduction losses.
- Higher operating frequency (100 kHz).
- ON-operating in ohmic region.
- Control turn-on & turn-off device.
- Smaller turn-off time because it does not have minority carrier storage.
- Control signal requirement continuously.
- Ratings : 1000V; 50A, 100 kHz
- Switching period, $t_s = 1\mu \text{ sec}$

1.6.3 IGBT

- Bipolar device.
- Voltage controlled device.
- Three terminal device : Emitter, collector and gate.
- Low forward voltage drop.
- Low on-state power loss than MOSFET.
- Low conduction loss than MOSFET.
- Having characteristics of BJT & MOSFET.
- Controlled turned-on & turned-off devices.
- Control signal requirement continuously.
- High input impedances.
- Positive temperature coefficient.
- Secondary breakdown not occur.
- Used for parallel operation.
- Ratings : 1200V, 500A, 50 kHz.
- Switching period, $t_s = 20\mu$ sec.
- Two terminal, three layer device : power diode, DIAC.
- Majority carrier device : MOSFET, SIT.
- Bipolar device : Diode, BJT, IGBT, MCT.
- Unidirectional device : Diode, SCR, LASCR.
- Bidirectional device : TRIAC, DIAC, BJT.
- Negative pulse turn-on device : MCT.
- Negative pulse turn-off device : GTO.
- Controlled turn-on & off device : BJT, MOSFET, IGBT, SIT MCT.
- Continuous control signal : BJT, MOSFET, IGBT, SITH.
- Uncontrolled device : Diode, DIAC.
- Bistable switch : SCR.
- Bidirectional current device : TRIAC, RCT.
- Unidirectional current device : Diode, SCR, GTO, BJT, MOSFET, IGBT, SITH and MCT.

○○○

PRACTICE SHEET

OBJECTIVE QUESTIONS

1. IGBT is used for applications in
- (a) Low Power (b) Medium Power
- (c) High Power (d) None of these

2. Which is the most suitable power device for high frequency (>100 kHz) switching application?
- (a) Power MOSFET
- (b) Bipolar junction transistor
- (c) Schottky diode
- (d) Microwave transistor

3. Match List-I (Converters) with List-II (Type of Conversion) and select the correct answer using the codes given below the lists:

List-I	List-II
A. Controlled Rectifier	1. Fixed DC to variable voltage and variable frequency AC
B. Chopper	2. Fixed DC to variable DC
C. Inverter	3. Fixed AC to variable DC
D. Cycloconverter	4. Fixed AC to variable frequency AC

Codes: A B C D

(a)	2	3	1	4
(b)	3	2	4	1
(c)	2	3	4	1
(d)	3	2	1	4

4. Match List-I (Power Electronic Devices) with List-II (Symbols) and select the correct answer using the codes given below the lists:

- List-I**
- A. GTO thyristor
- B. TRIAC
- C. IGBT
- D. BJT

List-II

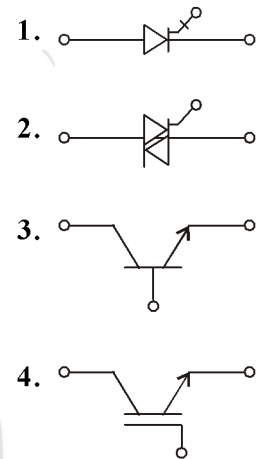

- Codes: A B C D
- (a) 1 2 3 4
- (b) 1 2 4 3
- (c) 2 1 3 4
- (d) 2 1 4 3
5. A gate-turn-off (GTO) thyristor
- (a) requires a special turn-off circuit like a thyristor
- (b) can be turned off by removing the gate pulse
- (c) can be turned off by a negative current pulse at the gate
- (d) can be turned off by a positive current pulse at the gate
6. The on-stage voltage of a GTO is
- (a) 0.7 V (b) 1-2 V
- (c) 2-3 V (d) >3

7. Match List-I (Power device) with List-II (Property) and select the correct answer using the codes given below the lists:
- | List-I | List-II | | | |
|--------------|------------------------|------------------------|------------------------|----------------|
| A. Thyristor | 1. Secondary breakdown | 2. Large on-state drop | 3. Small on-state drop | 4. Slow device |
| B. MOSFET | | | | |
| C. IGBT | | | | |
| D. BJT | | | | |
- Codes:**
- | | A | B | C | D |
|-----|---|---|---|---|
| (a) | 4 | 3 | 2 | 1 |
| (b) | 1 | 2 | 3 | 4 |
| (c) | 4 | 2 | 3 | 1 |
| (d) | 3 | 1 | 2 | 4 |
8. Which one of the following statement is TRUE for an 'ideal' power diode?
- Forward voltage drop is zero and reverse saturation current is non zero
 - Reverse recovery time is non-zero and reverse saturation current is zero
 - Forward voltage drop is zero and reverse recovery time is zero
 - Forward voltage drop is non-zero and reverse recovery time is zero
9. In a MOSFET, the pinch off voltage refers to
- drain to source voltage at which drain to source current is zero
 - gate-to-source voltage at which gate-to-source current is zero
 - drain-to-source voltage at which gate-to-source current is zero
 - gate-to-source voltage at which drain-to-source current is zero
10. Which one of the following diodes contains a metal-semiconductor junction?
- Tunnel diode
 - Zener diode
 - Schottky diode
 - Gunn diode
11. Resonant Converter's are basically used to
- Generate large peak voltage
 - Reduce the switching losses
 - Eliminate harmonics
 - Convert a square wave into a sine wave
12. Which of them is a disadvantage of power converters over conventional switch.
- High efficiency
 - small weight and good packaging
 - high Reliability
 - regeneration process is not easy .
13. Which of them is not characteristic of Ideal switch.
- Infinite current conduction capacity
 - Zero on state voltage drop
 - Infinite voltage blocking capacity
 - Zero off state resistance
14. Which of them is not a fully controlled device
- Power MOSFET
 - IGBT.
 - SCR.
 - GTO
15. Which one of them do not need continuous gate signal for triggering.
- MOSFET
 - IGBT
 - SIT
 - GTO
16. Which of them needs +ve pulse for turn off process
- SCR
 - GTO
 - IGCT
 - MCT.

17. Which of the device do not have control terminal.
- (a) SCR (b) Power diode
(c) Power BJT (d) IGBT
18. Which of them is not disadvantage of power Electronic converters
- (a) they produce harmonics
(b) they operate at low power factor
(c) they have high over load capacity
(d) Regeneration process is difficult
19. Which of them is correct VI characteristic of ideal switch
- (a)

(b)
- (c)

(d)
20. Low doping intensity is order of _____ in semi conductor layer.
- (a) $10^{10} \sim 10^{11}$ doping/cm³
(b) 10^{13-14} doping /cm³
(c) 10^{16-17} doping/cm³
(d) None of these
21. N-layer is added in power diode so as to
- (a) increase its conductivity
(b) increase its reverse blocking capacity
(c) Increase its switching speed
(d) None of these
22. On Increasing N⁻ layer in power diode
- (a) switching speed decreases
(b) conduction loss decreases
(c) efficiency of device increases
(d) None of these.
23. P-layer is not used generally in power electronic device because.
- (a) Its switching time is better than N-layer
(b) It offers more power loss than N-layer
(c) hole mobility is less than e-mobility
(d) None of these.
24. One of the disadvantage of using N-layer in PE devices
- (a) Conduction losses are high
(b) Malfunctioning of control terminal increases
(c) Reliability of device decreases.
(d) None of these
25. The VI characteristic of power diode is linear because of
- (a) N-layer in diode
(b) N layer in diode
(c) e-mobility is higher than holes
(d) depletion layer is large
26. ON state voltage drop of power diode is
- (a) 0.7 V (b) 0.3 V
(c) 1 V (d) 0.5 V
27. Which of these diodes have least turn on time:
- (a) general purpose diode
(b) Fast recovery diode
(c) Schottky diode
(d) Diode used in rectifiers

28. Which is not an application of power diode
- Welding
 - Traction
 - Modulation circuit
 - Battery charger
29. Which of the diode do not have a depletion layer in it
- Schottky diode
 - general purpose diode
 - fast recovery diode
 - None of these
30. Which of them is not application of fast Recovery diode
- Induction heating
 - Commutation circuits
 - Electroplating
 - SMPS.
31. Schottky diode has switching frequency of (Range)
- 10 kHz.
 - 200 kHz
 - 100 kHz
 - 2000 kHz.
32. During turn ON process of diode
- power factor is Low
 - power factor is unity
 - Power factor is leading
 - None of these
33. For a Ideal diode
- reverse recovery time should be less
 - reverse recovery time should be 0
 - softness factor must be 0.
 - softness factor must be 1.
34. Softness factor is defined as
- $\frac{t_b}{t_a}$
 - $\frac{t_a}{t_b}$
 - $\frac{t_a}{t_{rr}}$
 - $\frac{t_b}{t_{rr}}$
35. For the given points in reverse Recovery characteristic of diode depletion layer is restored / replenished at point
-
- B
 - C
 - D
 - E
36. In reverse recovery characteristic of diode, which is correct
- $t_a \gg t_b$
 - $t_{rr} \approx t_b$
 - $t_b \gg t_a$
 - None of these
37. Which of the relation is correct for reverse recovery of diode
- $I_{RM} = \left[\frac{Q_{rr}}{di/dt} \right]^{\frac{1}{2}}$
 - $I_{RM} = \left[\frac{2 \cdot Q_{rr}}{di/dt} \right]^{\frac{1}{2}}$
 - $I_{RM} = \left[\frac{Q_{rr}}{2di/dt} \right]^{\frac{1}{2}}$
 - None of these
38. If diode current is decaying at rate of 30 A/ μ sec and reverse recovery time is 3 μ sec. Find I_{RM}
- 135 μ A
 - 90 mA
 - 90 A.
 - 135 mA.
39. Which of them is not a transistor
- IGBT
 - MOSFET
 - SIT
 - MCT

40. Power transistor turns on when.
- $I_B > I_{BS}$
 - $I_B = I_{CBO}$ (Leakage current)
 - $I_B < I_{BS}$
 - None of these
41. Operating point on loadline characteristics of power BJT, operates on hard saturation line when.
- $I_B = I_{BS}$
 - $I_B < I_{BS}$
 - $I_B = 2I_{BS}$
 - $I_B = 4I_{BS}$
42. Primary Breakdown occur in power BJT. at
- $I_B = 0$; J_2 breaks
 - $I_B = I_{BS}$; J_2 breaks
 - $I_B = 0$; J_1 breaks
 - $I_B = I_{BS}$; J_1 breaks
43. Secondary Breakdown occur in power BJT. Due to
- $I_B > I_{BS}$
 - $I_B < I_{BS}$
 - heavy amount of electrons at J_2
 - Thermal Runaway.
44. During storage time of BJT Switching characteristic
- Charge gets store in base
 - Charge store in base are removed by re-combination
 - Charge store in all junctions gets removed by Removing load current
 - Charge gets stored in all junctions.
45. For a power Electronic device, if N^- layer is increased then
- Switching frequency decrease
 - More heat / conduction losses
 - Gate drive circuit rating increases
 - all of the above.
46. Which of them is not present during turn off process of BJT.
- Storage time
 - fall time
 - decay time
 - None of the above
47. Why negative pulse is utilized in turn off process of BJT.
- If Negative pulse is not given, BJT do not gets turn off
 - Negative pulse helps to turn off BJT early by clearing charges from base
 - Negative pulse make the conduction current to flow in negative (opposite) direction.
 - None of the above.
48. Which of the following is not an Application of MOSFET.
- Switch mode power supplies
 - Buck - boost Regulator
 - Inverter
 - Electroplating in Industrial process.
49. Power MOSFET is a
- Three terminal device
 - Three- four terminal device
 - four terminal device
 - None of the above.
50. Maximum operating frequency of a power MOSFET is
- 1 KHz
 - 10 KHz.
 - 100 KHz.
 - 10000 KHz
51. Which of the terminology is related to MOSFET static characteristic.
- Saturation Region.
 - Ohmic Region
 - Quasi- Saturation
 - Latch -up process.

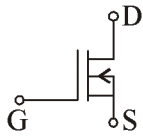
52. Which of the following method is good to turn on process for power Electronic Device having Junction in it .
- Increasing operating voltage across power terminals.
 - Increasing no. of charges at depletion Region
 - Increasing temperature of depletion Region every time
 - None of these
53. Which of the following is not a symbol of power MOSFET
- 

(a)

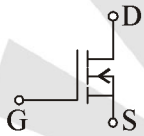

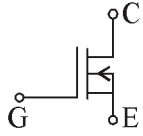
(b)
- 

(c)

(d) None of these
54. Power MOSFET turns ON when gate to source voltage is about
- 0.7 V
 - 1 Volt
 - 2-3 V
 - None of these.
55. As the p-type body terminal of N-channel MOSEFT is made more + ve Voltage:
- N- channel width increases
 - N- channel width decreases
 - N- channel width remains same.
 - eliminates discharging effect of gate terminal
56. In power MOSFET, N - channel is completed at
- $V_{GS} = V_{GST}$
 - $V_{GST} < V_{GS} < V_{GSP}$
 - $V_{GS} = V_{GSP}$
 - None of these
57. Choose the correct Statement about switching losses of device
- BJT > MOSFET > IGBT.
 - BJT < MOSFET < IGBT.
 - BJT > IGBT < MOSFET
 - BJT > IGBT > MOSFET
58. Choose the correct statement about input resistance of device
- BJT > IGBT > MOSFET
 - BJT > IGBT < MOSFET
 - BJT < IGBT > MOSFET
 - BJT < IGBT < MOSFET
59. Choose the correct statement about conduction losses of devices
- BJT > IGBT > MOSFET
 - BJT > IGBT < MOSFET
 - BJT < IGBT > MOSFET
 - BJT < IGBT < MOSFET
60. Match the correct characteristic of devices.
- | | |
|------------|--------------------------------|
| (1) MOSFET | (A) Latch -Up Problem. |
| (2) BJT | (b) Electric Discharge problem |
| (3) IGBT | (c) Secondary Break down |
- (a) 1 - B, 2 - C, 3- A
 (b) 1 - B, 2 - A, 3- C
 (c) 1 - A, 2 - C, 3- B
 (d) 1 - A, 2 - B, 3-C
61. IGBT has which of the Applications ?
- AC and DC Drives
 - UPS systems and power supplies
 - Drives for relay and contactors
 - All of the Above

62. Which of the IGBT combination is correct :
- (a) N – channel MOSFET + PNP BJT
 - (b) N – channel MOSFET + NPN BJT
 - (c) P– Channel MOSFET + PNP BJT
 - (d) None of these
63. IGBT loses its gate control when
- (a) e – current flows through MOSFET and PNP BJT
 - (b) e – current flows through MOSFET and NPN BJT
 - (c) e- current flows through NPN BJT and PNP BJT
 - (d) e– current flows through PNP BJT and Body Region.
64. If collector Current in IGBT increases beyond its rated value then
- (a) IGBT Gets damage instantly
 - (b) IGBT behaves as SCR
 - (c) IGBT behaves as BJT
 - (d) IGBT behaves as MOSFET
65. IGBT starts conducting when gate to emitter voltage is
- (a) 0.7 V.
 - (b) 1 Volt
 - (c) 2–3 V
 - (d) None of these

□□□



EA

ENGINEERS ACADEMY

ANSWERS AND EXPLANATIONS

1. *Ans. (b)*
IGBT is power semiconductor switch. It works at medium power level.
2. *Ans. (a)*
3. *Ans. (d)*
Controlled rectifier : fixed A.C. to pulsating (variable) D.C.
Chopper : Fixed D.C. to variable D.C.
Inverter : Fixed DC to variable voltage and variable frequency A.C.
Cycloconuerter : Fixed AC to variable frequency A.C.
4. *Ans. (b)*
5. *Ans. (c)*
6. *Ans. (c)*
7. *Ans. (c)*
8. *Ans. (c)*
9. *Ans. (d)*
10. *Ans. (c)*
11. *Ans. (b)*
12. *Ans. (d)*
13. *Ans. (d)*
14. *Ans. (c)*
15. *Ans. (d)*
16. *Ans. (d)*
17. *Ans. (b)*
18. *Ans. (c)*
19. *Ans. (c)*
20. *Ans. (b)*
21. *Ans. (b)*
22. *Ans. (a)*
23. *Ans. (c)*
24. *Ans. (a)*
25. *Ans. (a)*
26. *Ans. (c)*
27. *Ans. (c)*
28. *Ans. (c)*
29. *Ans. (a)*
30. *Ans. (b)*
31. *Ans. (d)*
32. *Ans. (a)*
33. *Ans. (b)*
34. *Ans. (a)*
35. *Ans. (b)*
36. *Ans. (a)*
37. *Ans. (b)*
38. *Ans. (c)*
39. *Ans. (d)*
40. *Ans. (a)*
41. *Ans. (d)*
42. *Ans. (c)*
43. *Ans. (d)*
44. *Ans. (b)*
45. *Ans. (d)*
46. *Ans. (c)*
47. *Ans. (b)*
48. *Ans. (d)*
49. *Ans. (b)*
50. *Ans. (d)*
51. *Ans. (b)*
52. *Ans. (b)*
53. *Ans. (c)*
54. *Ans. (c)*
55. *Ans. (b)*
56. *Ans. (c)*
57. *Ans. (d)*
58. *Ans. (d)*
59. *Ans. (d)*
60. *Ans. (a)*
61. *Ans. (d)*
62. *Ans. (a)*
63. *Ans. (c)*
64. *Ans. (b)*
65. *Ans. (c)*

**ENGINEERS ACADEMY**